



SOBY.COM
TRUSTED SINCE 1961



SØBY

R14 - R25

R40 - R60

Aspiration cleaners

SØBY aspiration cleaners are an economical solution for the cleaning of grain and similar crops.



Aspiration cleaners

Aspiration cleaners remove lightweight particles such as dust, shells and husks by means of air. The material is fed into the centre of the aspiration cleaner, where it is distributed onto the rotating turbine blade. The light particles are sucked up into the blower and heavy particles fall down into the outlet hopper.

Scope of application

Aspiration cleaners are used to separate light particles from crops. The aspiration cleaner is often placed in connection with a chain or bucket elevator as a key component in the conveying system. This enables it to be used both for cleaning incoming wet grain and for dry grain taken from storage. The best cleaning performance is achieved when the material is dry.

Accessories:

- Support stand
- Inlet hopper
- Rain cover
- Cyclone
- Filter box
- Dust bags
- Air throttle valve and rain cowl for cyclone

Basic machine:

- Fan with motor
- Outlet hopper
- Suspension bracket
- Inspection window
- Regulator valve
- R14-R25 painted finish
- R40-R60 galvanised
- R14-R25 inlet/outlet Ø150
- R40 inlet/outlet Ø200
- R60 inlet Ø200, outlet Ø250
- Fan outlet R14 (Ø150) and R25 (Ø200)
- Fan outlet R40-R60 Ø300
- Fan size R14 (0.75 kW), R25 (2.2 kW), R40 (5.5 kW) and R60 (7.5 kW)

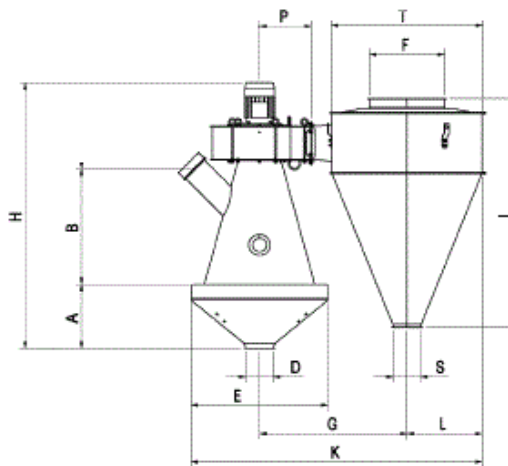

Type	A	B	D	E	F	G	H	I	K	L	P	S	T
R14	241	450	150	502	300	617	1139	892	1144	276	197	150	600
R25	338	616	150	725	400	783	1409	1211	1544	399	275	200	800
R40	475	877	200	1000	400	1039	2160	1369	1937	399	363	200	800
R60	475	877	200	1000	400	1039	2160	1369	1937	399	363	200	800
*R40/R60	475	877	200	1000	400	1380	2160	2469	2285	405	363	200	700

SOBY TRUSTED SINCE 1961

Viborgvej 306 · DK-7840 Højslev
 (+45) 97 53 50 33 · soby@soby.com
 www.soby.com