



**SOBY**.COM  
TRUSTED SINCE 1961



# SØBY SK5-SK12 Bucket elevators

SØBY bucket elevators are an economical and reliable solution for vertical conveying of small quantities of grain, seeds and ground bulk products.



## SØBY bucket elevators

SØBY SK5-SK12 bucket elevators are an economical and reliable solution for the vertical conveying of small amounts of grain, seeds and ground bulk products. SØBY SK5-SK12 bucket elevators are available in different sizes with capacities from 5 to 12 tonnes/h.

- Hot-dip galvanised
- Extensive product range ensures great flexibility
- Elevator head with wearing plate
- Moderate oil-resistant elevator belt
- Extension sections with Q16 flange connections
- Many different inlet and outlet combinations

## Scope of application

Due to very compact built-in dimensions, SØBY bucket elevators are ideal for installation anywhere in the grain conveying line where vertical conveying is required. Bucket elevators are available in heights of up to 18m.

## Accessories:

- Rotation sensor that indicates whether the elevator is running
- Belt indicator that indicates whether the belt is out of alignment

## Basic machine

- Elevator head with wearing plate
- Elevator foot with tensioning device
- Inlet and outlet SK5-12 Ø150 or Q16, inlet Ø150 or Q20 60°
- Alternatively with inlet for direct installation of ST152 trough auger
- Motor bracket with directly coupled gear and motor
- Various extension sections, including 1 extension section with inspection window.
- Moderate oil-resistant elevator belt (fully oil-resistant belt available on request), elevator buckets, bucket bolts and fittings

## Plate thickness:

- Head: 2 mm
- Foot: 2 mm
- Extension section: 2 mm

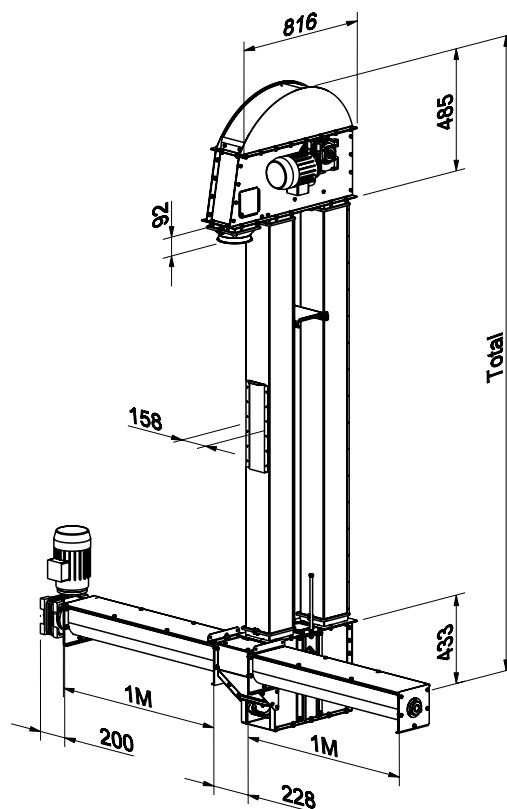

**SØBY** TRUSTED  
SINCE 1961

Viborgvej 306 · DK-7840 Højslev  
(+45) 97 53 50 33 · soby@soby.com  
www.soby.com