



SOBY.COM
TRUSTED SINCE 1961



SØBY SS205-SS254 Grain augers

SØBY grain augers are an internationally renowned quality product that can be incorporated wherever grain and ground bulk products need to be conveyed. Conveying systems with SØBY grain augers can always be extended or adapted as and when needs change.



SØBY Grain augers

Galvanised and with flanged joints.

Scope of application

SØBY grain augers have a wide range of applications in agriculture and the animal feed industry for conveying grain and ground bulk material.

Basic machine

SS205 with belt drive:

- 1m auger head with Ø200 outlet, Motor bracket, V-belt drive with guard and drive shaft with double bearings.
- Extension sections 0.5 - 1 - 2 and 3 m with flanged joints
- 1m auger foot with protective grating and inlet regulation
- Motor pulley
- Motor

SS205 with gear motor:

- 1m auger head with Ø200 outlet, gear motor
- Extension sections 0.5 - 1 - 2 and 3 m with flanged joints
- 1m auger foot with protective grating and inlet regulation

SS254 with gear motor:

- 1m auger head with square outlet
- Outlet hopper Q24
- Transition Q24 to Ø250
- Extension sections 0.5 - 1 - 2 and 3 m with flanged joints
- 1m auger foot with protective grating and inlet regulation

Accessories:

- Fig. 1: Auger foot / outlet with shaft and bearing (Ø200)
- Fig. 2: Long inlet with slide
- Fig. 3: Hopper with grate, fits long inlet
- Fig. 4: Bottom bearing with shaft

SS205-SS254

Capacity is based on dry and clean grain 0.75 t/m³

Capacity t/hour	Horizontal	45°	Auger rpm
SS205 (belt)	60	42	450
SS205 (gear)	55	40	400
SS254	90	72	400

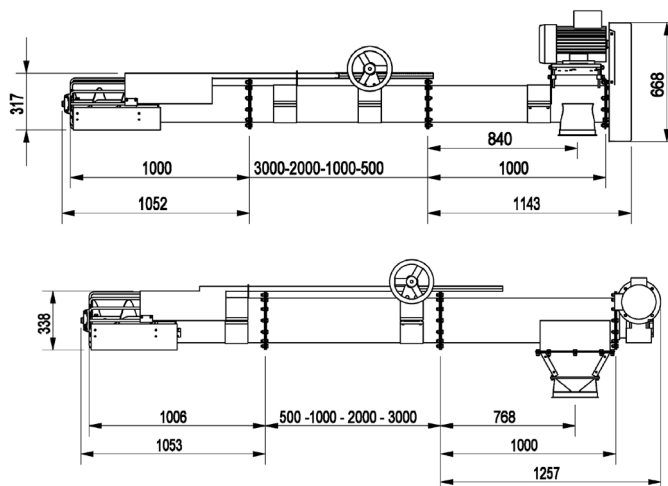
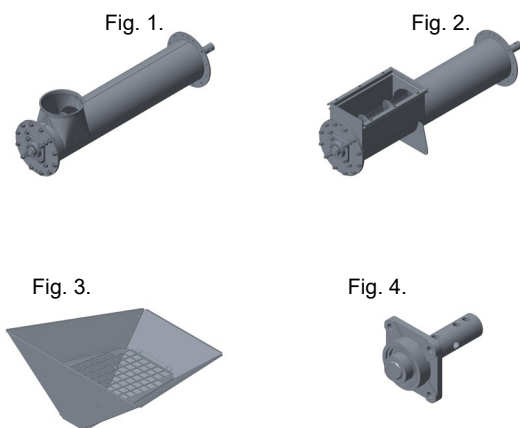

SØBY TRUSTED
SINCE 1961

Viborgvej 306 · DK-7840 Højslev
(+45) 97 53 50 33 · soby@soby.com
www.soby.com