



SOBY.COM
TRUSTED SINCE 1961



User manual

SS102-152

Thank you for choosing SØBY
In order for the machine to function
optimally, it is important to forllow the
instructions in this manual.

Enjoy.

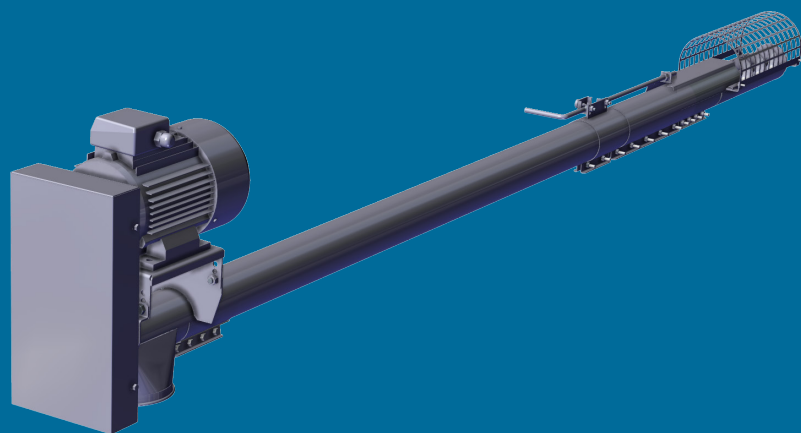

Introduction

Thank you for choosing SØBY.

It is very important that you read this user manual to obtain the necessary knowledge regarding installation, operation, service, maintenance, and dismantling. It is important to keep the user manual in a safe location for future use.

At SØBY we always work to improve our machines therefore we reserve the right to improve and update our products continually. This mean that some machine parts will be removed from the product selection, but it will always be possible to get a corresponding machine part for our machines. SØBY will always be ready to help and guide regarding our products.

Enjoy.

Contents

General Information	3
Safety Instructions	6
Use of the Machine	8
Explanation of the Pictograms	9
Residual Risks	10
Description of the Components.....	11
Mounting.....	12
Operation	18
Maintenance	18
Technical Data.....	20
TroubleShooting	21
Declaration of Conformity	22

General Information



Please read the entire User Instructions before assembling and operating the installation.

If the purchaser makes any technical modifications to the machine, then any warranty from SØBY is cancelled. The declaration will lose its validity.

The guarantee is only granted, if the following conditions are met:

- The unit only is to be used as described in this User Instructions. Replacement of parts or changing in the construction of the device might cause that the equipment must be re-certified.
- Assembly, putting into operation and operation only by using this User Instructions.
- Compliance with the intervals for maintenance in accordance with instructions must be documented.
- The area where the equipment is going to be installed must be selected or adapted so that the unit is not unnecessarily exposed to mechanical stresses from the environment, resulting in damage of the equipment.
- Only use the original spare parts of the manufacturer.
- In order to prevent dust emissions, all joints must be sealed by silicone.
- Emergency stops must be installed in accordance to current standard EN 60204-1.
- Open inlets must be equipped with rack in a sufficient safety distance, see valid Machinery Directive and the Directions of the National Labour Inspection (DK). One must show particular vigilance by auger foot inlet with basket, so that there from the auger will be a sufficient safety distance when the machine is in operation. Minimum distance of 850mm from rack to auger with a requirement of a current mesh size of up to 40mm, according to valid DS/EN ISO 13857.
- At normal operation at the machine, one must look into the pictogram devices and study the User/Assembly Instructions.
- When performing operations in areas where there might be a risk of explosion, the safety of personnel and equipment depends on compliance with the relevant safety regulations. Performing installation works and maintenance in such areas, involves a special responsibility of the people who are carrying out the works. The works mentioned requires that the assembly personnel and maintenance personnel have a thorough knowledge of laws, regulations and standards within the area. This construction provides a brief review of the most important safety issues, which are associated with installation, maintenance and use of the equipment. Please pay attention to the fact, that the end user has the final responsibility of identifying any possible explosion hazardous areas according to current regulations, with the following requirements for zone classification and possible reporting to the local authorities.

- Repair, service and maintenance must be performed carefully in strict compliance with the instructions of SØBY and must be performed by personnel who possess the qualifications required for the taking care of the explosion safety of the equipment. Inspection and maintenance must be based for the electrical equipment concerned on the instructions in EN60079-17.
- During the lifetime of the fan concerning the mechanical parts, and in connection with use, there must be a particularly focus on:
 - Service lifetimes (see chart)
 - Damages to pipes and shieldings
 - Corrosion
 - After tightening of bolts and screws
 - Control of belts, hereunder after tightening
- Modifications or alterations of the equipment, which influence the explosion safety of the equipment, are not allowed. Before using the equipment, check that the equipment is undamaged, assembled, and installed as directed by SØBY.

Attention is in particular drawn to:

- National Security Rules
- National Requirements to Safety and Health at Places of Work
- National Rules of Installation for the Type of Installation in Question
- Recognized Standards
- Safety Information in this Instructions for Operation
- Data and Information on the Permissible Installation and Operating Conditions of the Rating Plate
- Directions in any Type Certificates for Equipment installed on the Unit

The manufacturer reserves the right of performing technical changes.

The machine can be used for transportation of feedstuff, which gives reason for an inner Zone 22. In that case the machine is to be installed in an Atex zone, one must select suitable gear and motor.

The machine can be used for transportation of the following materials, with data, which are shown in the following:

- Cereal, mixed dust
- Flour/meal
- Minerals
- Soya bean crushed corn/meal
- Rape/beans

	Particle Size [µm] [Microns]	Ignition Temperature Cloud of Dust [°C]	Ignition Temperature. 5mm Layer of Dust [°C]	LEL [g/m ³]	MIE [mJ]	Kst [bar m/s]	Reference
Limit Values	12	400	280	30	50	131	-

If the medium, which is transported, contains stones or metal parts, the explosion safety cannot be guaranteed.

Must comply with EN 60079-10-2:2015 concerning explosive atmospheres/atmosphere of dust.

Safety Instructions



The manual and especially information concerning safety must be read carefully prior to assembling, operating, servicing and maintaining.

All installations and components must be assembled in accordance with the relevant regulations for prevention of accidents.

The machine must be shielded correctly in relation to the relevant Machinery Directive. Therefore, that it will be impossible to encounter moving parts. All pointed out shieldings must be mounted before the machine is put into operation. All shieldings may only be removed by using tools. The shieldings must be mounted before the machine is put into operation.

The motor must be properly protected through overload protection equipment. Just like the auger properly must be ensured capable potential compensation.

At any repair or maintenance, the power source must be separated from the drive motor.

When the pipe auger is running, do not put your hand or your fingers into the drive device or into the control throttle.

Shieldings and also belt shielding and inlet coverings for prevention or elimination of risks must be maintained regularly.

The machine must be installed in such a way that there are ergonomic good conditions at service at the machine.

Safety equipment, which has been removed during repair, cleaning or maintenance, must be re-established before the installation is put back into service.

All screws, bolts and trailed things must be properly tightened.

If the machine gets stuck/clogging, it may result in overheating of the transmission.

The auger may only be put into operation when it is assured that it is not defective. The user is obliged only to operate the system, when it is in perfect condition.

SØBY is not liable for damages arising from misuse or technical alterations to the system and breach of the instructions given in these Instructions of Use.

If the pipe auger is placed in areas classified as potentially explosive, use specially approved motor for that zone. If in doubt, please contact SØBY for further information. It must be ensured that the ambient temperature in the area in which the equipment is going to be placed, remains within the allowed limit values of the equipment $-20^{\circ}\text{C} \leq \text{TA} \leq 40^{\circ}$. Therefore, one must, at installing of the unit take into account, that there might be possible heat sources that could affect the ambient temperature in the area in which the equipment is installed.

During any kind of work with the auger, there must be adequate work lighting

During any kind of work with the machine should be used, safety boots, earmuffs and other required precautions as they might be required by the local workplace assessment, in which the auger is going to be installed. Furthermore, helmet must be used during installation, service and assembly/disassembly.

When assembling of machines, there might be heavy lifting. People who set up the machine must read the assembly/user manual at first. Suitable lifting equipment must be used in connection to installation and assembly.

As there might be a danger of sharp edges, one must use gloves when handling the machine.

The equipment must not be exposed to more dust impact (dust layers) than allowed in EN 60079-14.

You should be aware that if the auger is expected to run empty for more than 30 seconds a dry-running sensor must be mounted, which ensures that the machine stops. Likewise, it is ensured that the machine outlet will not be clogged. For example, by using a stop report/detector. If there are jarring sounds from the machine during operation one has to find the cause of the jarring sounds, and defective parts must be replaced.

Use of the Machine

The pipe auger is designed for horizontal and inclined transportation of grain and almost of all cereals, seeds and flour products available within agriculture (see page 5 about material specifications in General Specifications). The pipe auger can be used in an angle up to 45°. The pipe auger **may not** be used for tasks beyond these ones.

The pipe auger may have a speed of 140-1000 rpm at the auger. Maximum lengths of 12m.

Explonation of the Pictograms

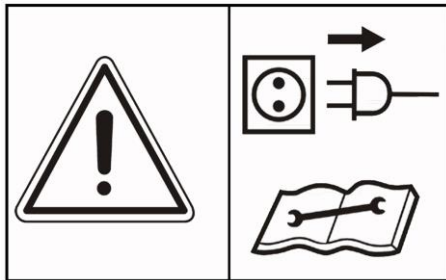

Prior to repair, maintenance and cleaning work the motor must be turned off and the electric plug pulled out, or the safety lock should be locked in the open position.

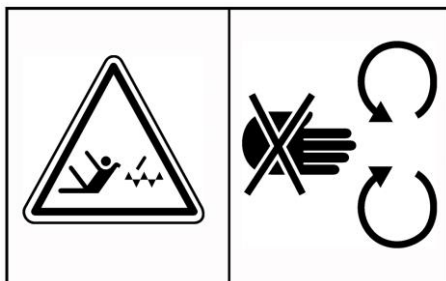

Moving parts of the machine can be dangerous.
All shieldings must be mounted before starting up of the machine.



Hearing protection is required when working with this machine.



Sealing for belt shielding can be turned according to the location of the motor, relative to the belt shielding. (See Description of the Parts of Sealings).

Residual Risk

The pipe auger is produced in accordance with the health and safety requirements, which are set out in the ATEX and in the Machinery Directive, and in accordance with the consequently harmonized standards. If these regulations are disregarded, the pipe auger might be a danger to the operator/user or to the life and limb of a third party. See Declaration of Conformity.

Description of the Components

Head of the auger w/ motor bracket and belt drive

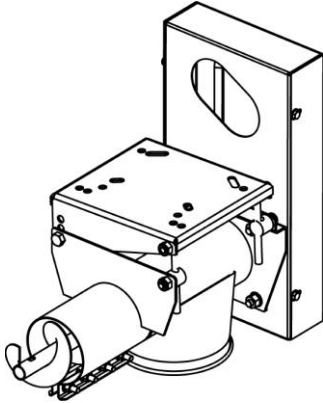

Head of the auger w/ gear motor

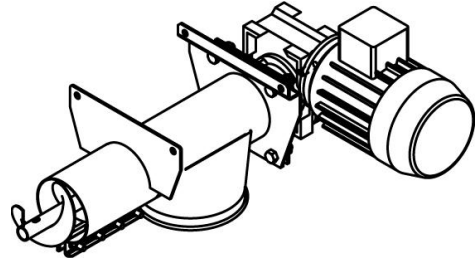

Foot of the auger, inlet w/ basket

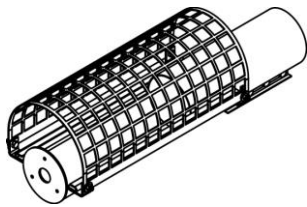

Inlet regulation for inlet w/ basket

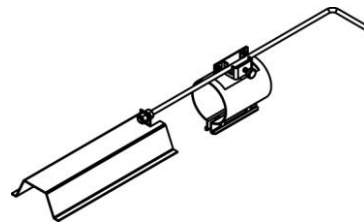

Oblong inlet w/ or w/out throttle

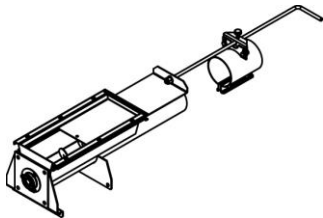

Auger Foot, inlet/outlet

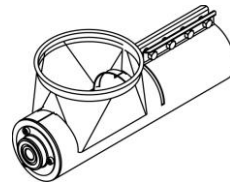

Extensions w/ spigot and socket

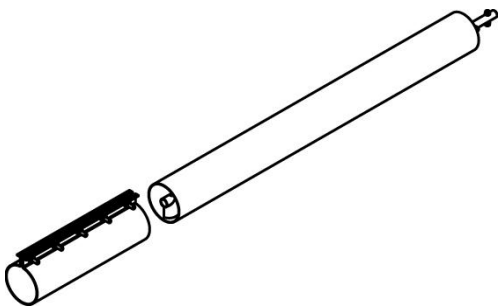

Bottom bearing

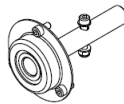

Carry support/frame

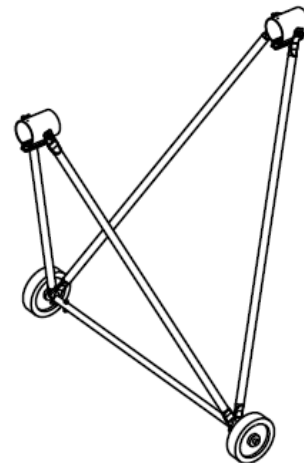

Sealing

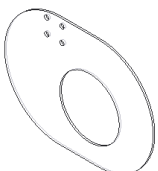

Mounting

Technical knowledge is prerequisite for assembling of pipe augers.

Head of the Auger w/ Belt Drive

Heads of the pipe augers are delivered already assembled.

The inner pipe auger is pulled via the tie bolt a little out from the external pipe of the extension and is connected to the inner pipe of the head of the auger, so that the convolution of the respective ends of the auger align. The external pipe of the extension should be pushed into the head of the auger up to the edge of the outlet, (See figure 1 position 1).

Further extensions are mounted by the help of the socket w/ the half over both ends of the pipe.

Figure 1

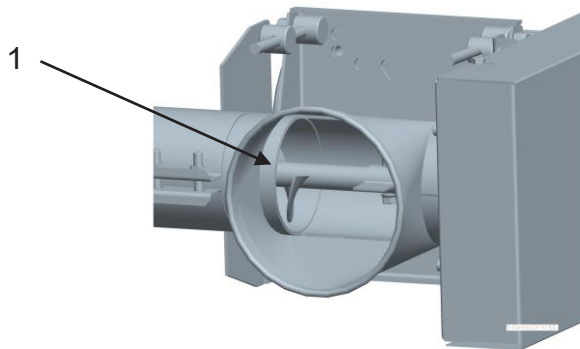

Foot of Auger, Inlet w/ Basket

The foot of the auger is to be pushed onto the extension pipe and to be screwed firmly, (see figure 2).

If the auger has been delivered with inlet regulation, the steering socket for regulation must be pushed onto the extension pipe before the foot of the auger is to be mounted.

If an end bearing is going to be used, the internal auger must be fitted to the end-bearing spigot before the foot of the auger is screwed firmly.

Put the operating lever w/ the collar band onto the external pipe of the auger, while the inlet slide is pushed all the way down. The function is controlled by pushing the operating lever.

Figure 2

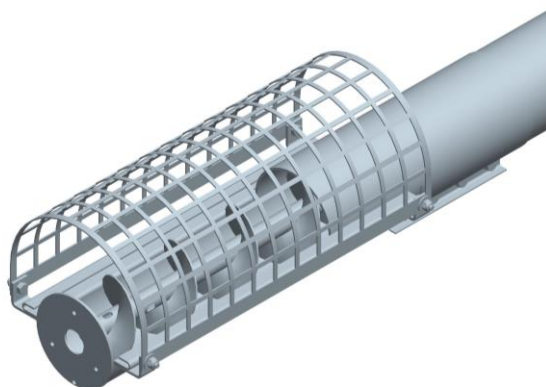

Foot of the Auger, Round Inlet

Foot of the auger, round inlet, is in principle mounted in the same way as at foot of the auger w/ basket, however, it is necessary to shorten the inner auger by 140mm, see figure 3 position 1, and drill a new hole for the end-bearing spigot.

Figure 3

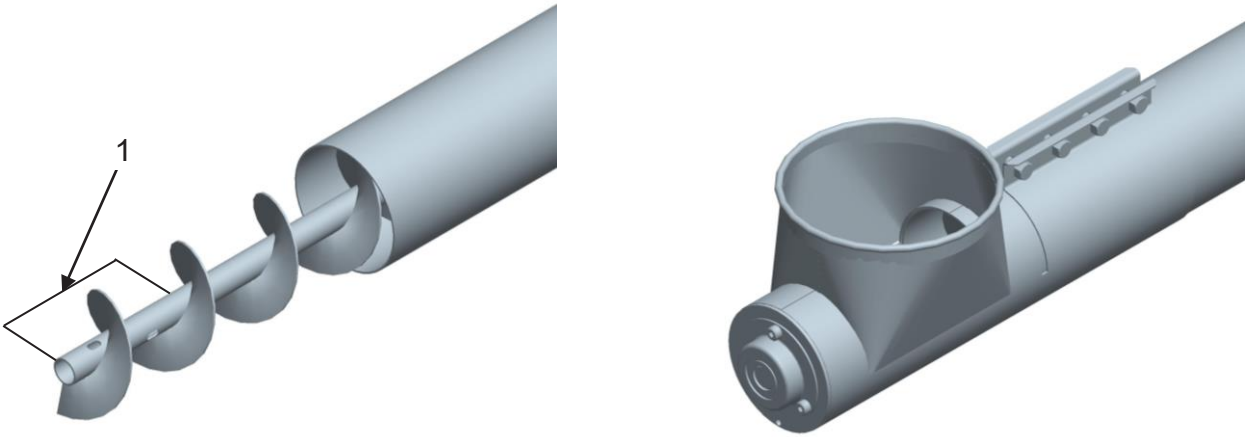

Oblong Inlet

Oblong inlet is mounted with the help of a steering knuckle, just as if one assembles the extension. At first one dismounts the inner auger inside the oblong inlet and it is screwed together with the inner auger from the extension. Here after the steering knuckle is pushed onto the extension pipe, the oblong inlet is placed and the steering knuckle is put with one half over both pipe ends. Eventually the bolt is screwed firmly into the end steering knuckle, see figure 4.

If the auger has been delivered with an inlet regulation, then the steering knuckle for regulation must be pushed onto the extension pipe before the oblong inlet is mounted. The operating lever w/ the collar lever is put onto the external pipe of the auger, while the inlet slide is pushed all the way down. The function is controlled by pushing the operating lever.

Figure 4

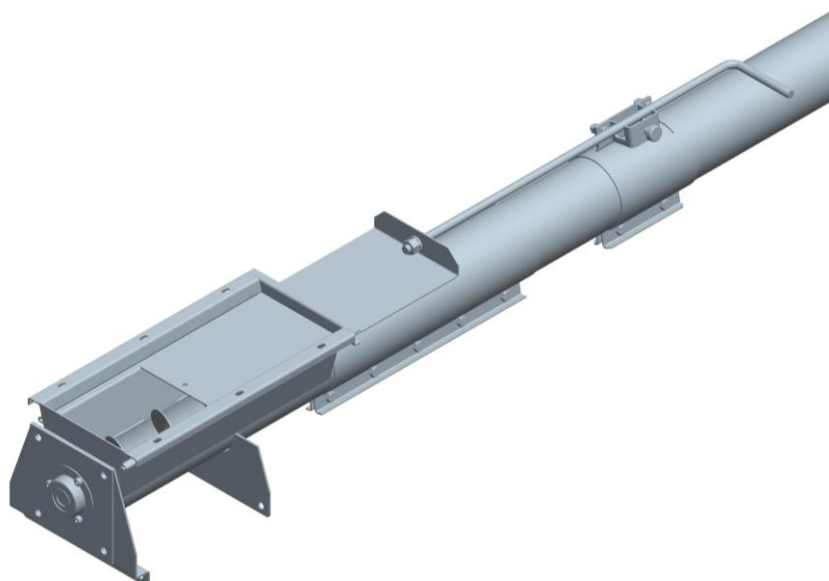

Mounting of Motor and V-Belt Pulley

The protective plate (the cover/lid) is to be removed. The large wheel of the V-belt pulley and the taperlock-bush are to be connected loosely together (see special-instructions), and are to be pushed onto the drive shaft of the auger and are to be tightened firmly by two threaded pins.

The motor must be fitted onto the motor bracket by 4 screws. The V-belt-tighten-device is to be turned totally down. The small wheel of the V-belt should be pre-mounted and to be pushed into the motor shaft. The two wheels of the V-belt must be put into position, so that they flush with one another. Hereafter the two threaded pins must fix the small wheel of the V-belt. The V-belt is mounted and tightened so much, that the belt only just can be pushed 7-8 mm to the inside. The protective cover/lid for the V-belt is to be mounted again.

Taperlock

Figure 5

In order to secure the pulley onto the shaft, tighten the threaded pins in the 2 holes opposite to each other position 1

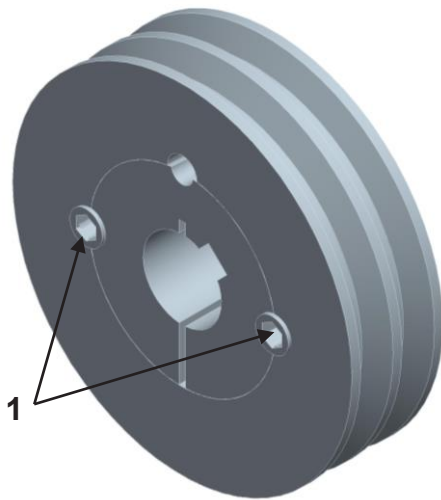

In order to loosen the taper-lock bushes, the threaded pins are to be screwed out, one of these threaded pins are again to be turned into the third hole, position 2 and are to be tightened

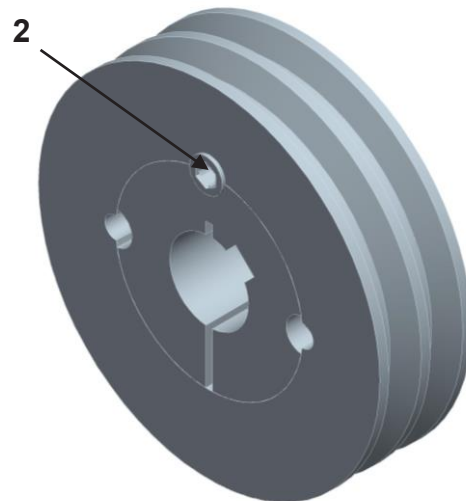

Head of the Auger w/ Gear Motor

The head of the auger and extensions are mounted as at the head of the auger w/ belt drive.

Sealing of Flange between Gear and Motor

The assembly is to be jointed at the upper side, in order to prevent ingress of water.

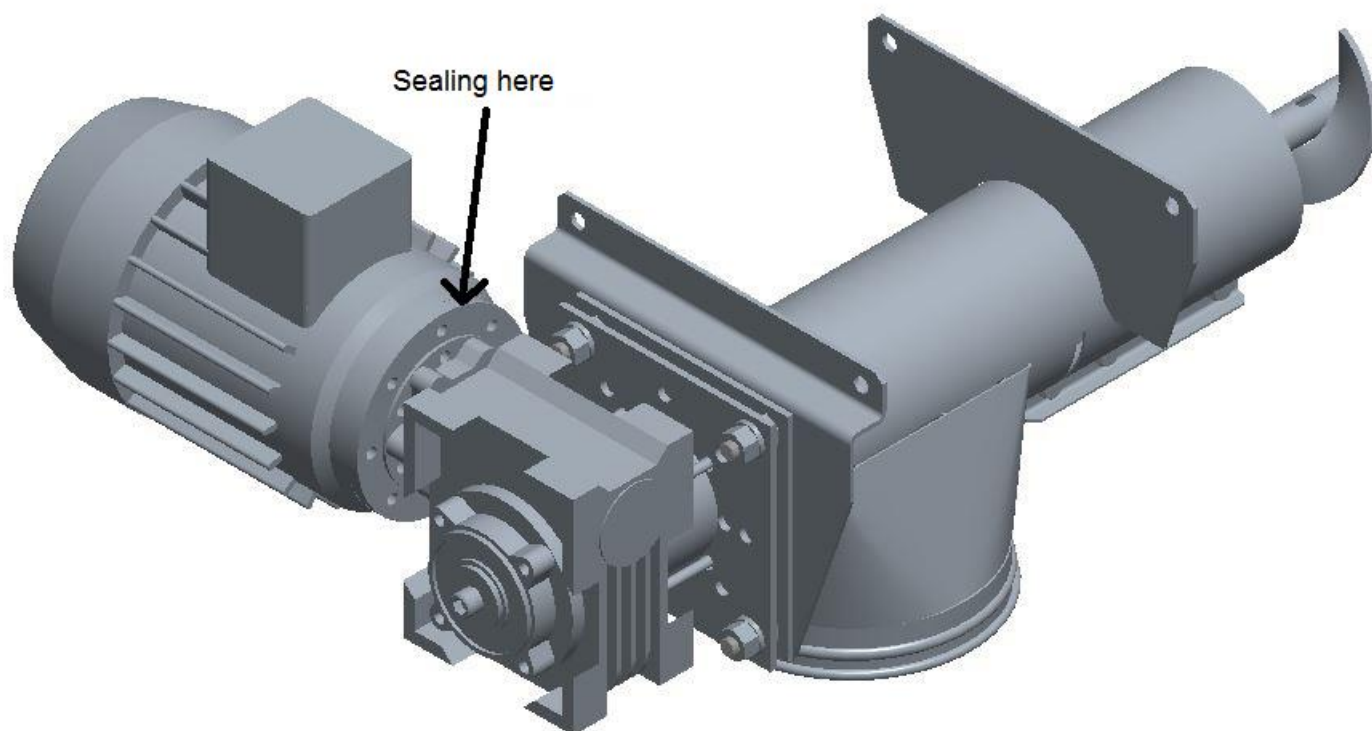

Supports

The pipe auger must have supports for each 6m and joints between parts must be properly carried out. At grain cannon must use a suitable rack in order for proper balance. If in doubt, please contact SØBY.

Description of the location of brackets for grain cannon:

SS102-152 45° (Do not angle more than 45°):

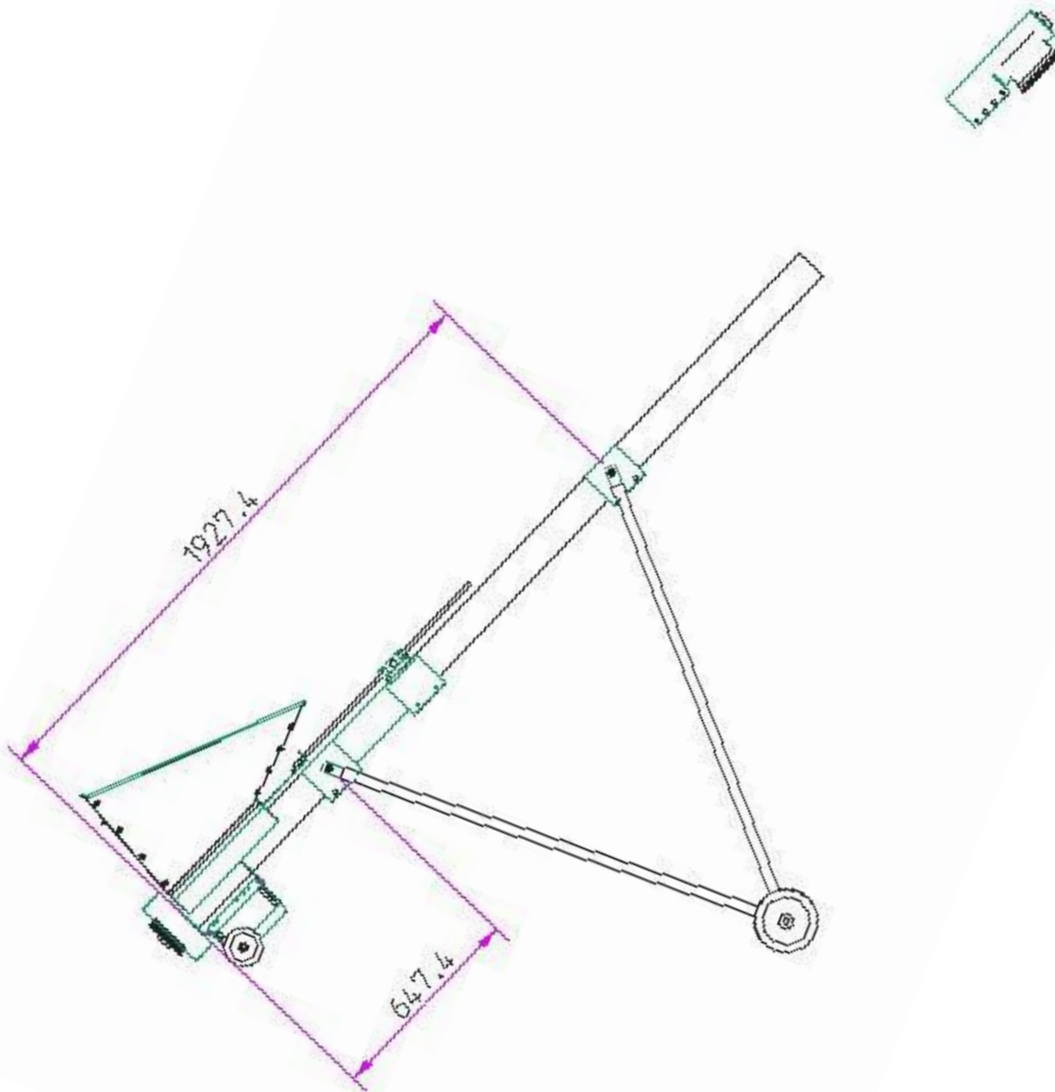

Electrical Equipment

Specially trained staff only may perform the electrical connection to machinery delivered by SØBY.



During installation, be aware of the voltage and data indicated at the motor data plate.

The connection terminals of the motor are connected according to the instructions on the motor. The motor must be protected with thermal protection and by a lockable main cutout switch, as the guarantee from the motor manufacturer else will be nullified (This equipment is not included in the delivery standard).

Installation of connection of the unit must take place in accordance with national rules of installation, supplemented by the demands, which are stated in the Heavy Current Regulations nos. EN60204-1 and EN60079-14. Starting up of the electrical parts and subsequent maintenance must be in accordance with the instructions in EN60079-17.

Incidentally, we refer to the directions of the manufacturer for the motor and gear and possible demands for intervals of maintenance and service, concerning steady enforcement of the explosion security of these parts.

If a frequency converter is installed, one carefully has to take stock of data from the converter and from the data plate. Pay attention to the labeling of the electrical components in classified areas.

Balancing of the potential:

An outside terminal for connection to the equalizer exists.

The connection must be carried out in accordance with the instructions in EN60079-14.

When the pipe auger is connected, check the direction of rotation according to the arrow.

Figure 6



Operation

During operation of the pipe auger, the relevant regulations for prevention of accidents must be observed.

Add transport material to the pipe auger (See chart page 5 upper) and control if this can freely run through.

Avoid running the pipe auger empty, as this cause huge wear of the bends of the auger, and hereby the pipe auger also will make more noise and danger of explosion might arise.

During normal operation, the auger will be totally filled up.

Maintenance

During maintenance works, the safety regulations, which are described in the section Safety Instructions, must be observed.

The tension of the drive V-belt should be checked every 3 months. At frequent use of the pipe auger, the tension of the drive V-belt must be checked every month. At the tightening of the belt, one should look for abrasion, if this is the case, the belt must be changed immediately. If this is not any longer possible, the V-belt must be changed.

The inner augers are worn more or less, depending on how much dirt there is in the material transported, and once a year one has to control for abrasion or damages. Damages at the inner augers may arise via foreign objects, such as for instance pieces of wood, stone or iron.

If foreign objects are stuck inside the auger, these can be removed by using appropriate tools, but under no circumstances by your own hands. In such case, one has to take apart the pipe auger. The inner auger must be replaced, if it is too worn out.

Please be aware of that securities of motors, gearings and bearings are subject of compliances of intervals of maintenances/replacements.

The following equipment at the unit is going to be maintained with the following intervals:

Equipment	Manufacturer	Intervals of Maintenance:
Top bearing	PTI	Must be replaced at every 10.000 operating hours.
Bottom bearing	PTI	Must be replaced at every 10.000 operating hours.
Belt	PTI	The tension of the drive V-belt should be checked at each 1.000 operating hours. At frequent use of the pipe auger, the tension of the drive V-belt must be checked every month. At the tightening of the belt, one should look for abrasion, if this is the case, the belt must be changed immediately. If this is not any longer possible, the V-belt must be changed. The V-belt must be antistatic and flame retardant.
Belt pulley	PTI	Must be replaced at every 10.000 operating hours.
Motor	Cantoni /techtop	Must be replaced at every 20.000 operating hours.
Gear box	Varvel	It is important to emphasize that the explosion safety is subject to the fact that there will be carried out the below demanded maintenance: Dust layer more than 5 mm must be removed by vacuum-cleaner For every 500 hours of operation, seals must be controlled for leaks For every 3.000 hours of operation or for every 6 months, a visual inspection of oil seals must be carried out and in cases of signs of abrasion, the seals must be replaced. Oil changes are to be carried out every 5 years.
Pipe of the auger	SØBY	Must be controlled for signs of corrosion for every 1.000 operating hours

Technical Data

Noise Level: Operation w/ grain 81,8 dB(A)
 Half Empty 85,6 dB(A)
 Total Empty 92 dB(A)

Motor Capacity: Between 1,5 kW and 5,5 kW. See nameplate of the motor for further information.

Gear: Varvel RT/RS
 Synthetic gear oil ISO VG 320 "long-life" oil

Transport Capacity: SS102 up to 18 tons/hour horizontal
 SS127 up to 25 tons/hour horizontal
 SS152 up to 41 tons/hour horizontal

Dimensioned Sketch

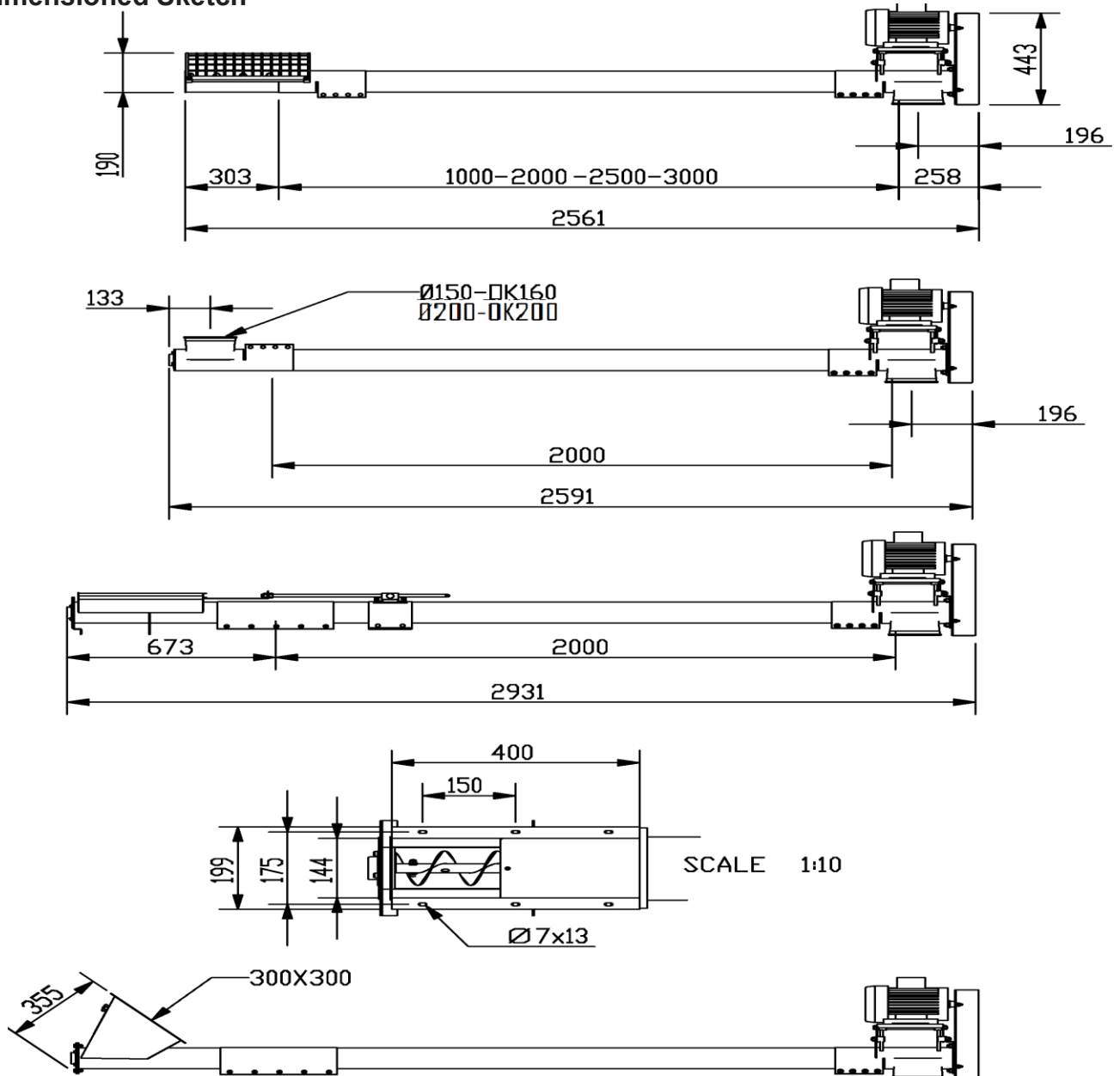

Technical Data

Noise Level: Operation w/ grain 81,8 dB(A)
 Half Empty 85,6 dB(A)
 Total Empty 92 dB(A)

Motor Capacity: Between 1,5 kW and 5,5 kW. See nameplate of the motor for further information.

Gear: Varvel RT/RS
 Synthetic gear oil ISO VG 320 "long-life" oil

Transport Capacity: SS102 up to 18 tons/hour horizontal
 SS127 up to 25 tons/hour horizontal
 SS152 up to 41 tons/hour horizontal

Dimensioned Sketch

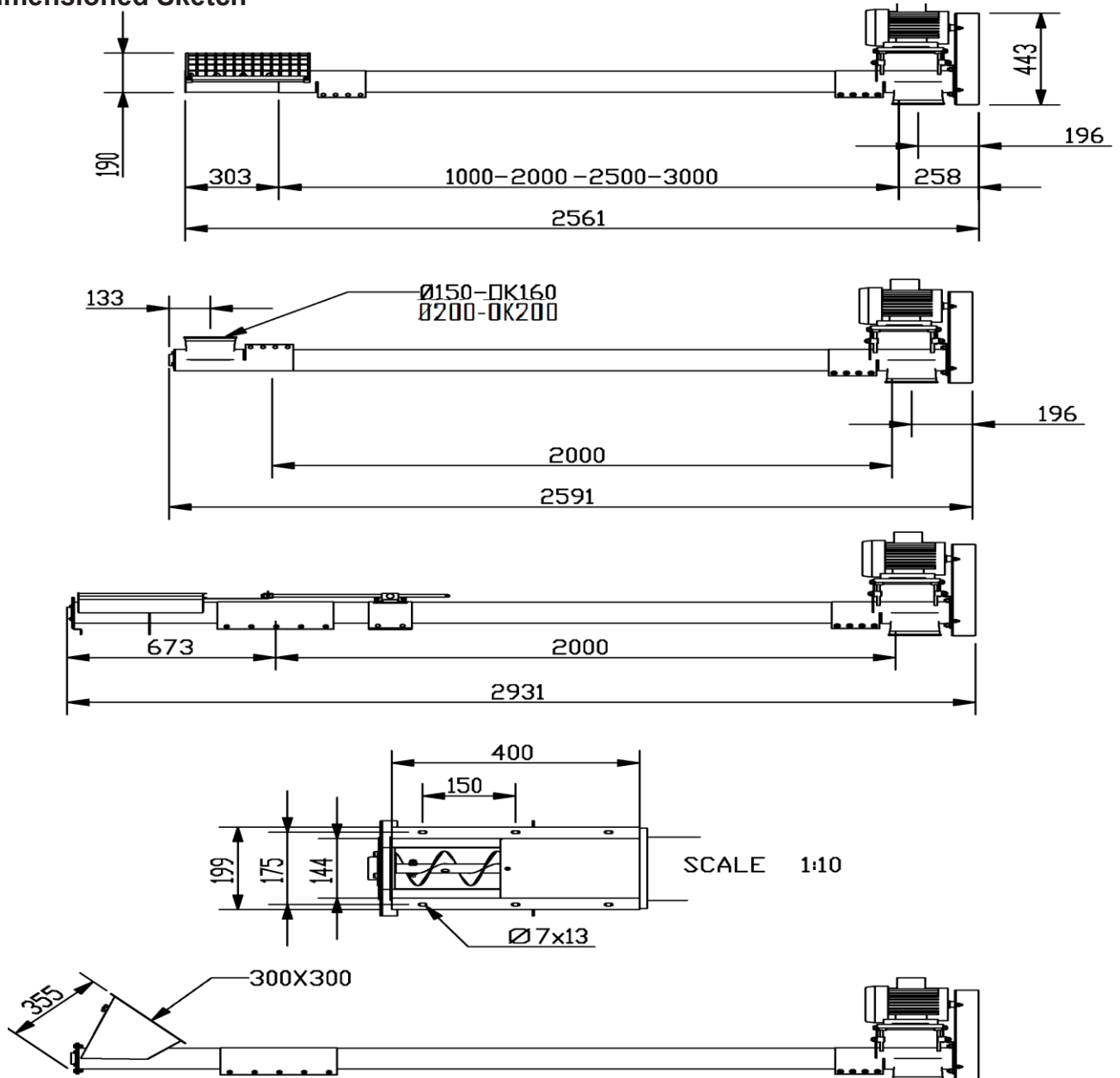

Lengths of Pipes	SS102 Auger rpm 1000 Motor 1400 rpm	SS127 Auger rpm 800 Motor 1400 rpm	SS152 Auger rpm 700 Motor 1400 rpm
3m	1,5 kW	2,2 kW	2,2 kW
4m	1,5 kW	2,2 kW	3,0 kW
5m	1,5 kW	2,2 kW	3,0 kW
6m	2,2 kW	3,0 kW	4,0 kW
7m	2,2 kW	3,0 kW	4,0 kW
8m	2,2 kW	3,0 kW	4,0 kW
9m	2,2 kW	4,0 kW	4,0 kW
10m	3,0 kW	4,0 kW	5,5 kW
11m	3,0 kW	4,0 kW	5,5 kW
12m	3,0 kW	4,0 kW	5,5 kW

TroubleShooting

Errors	Possible Cause	Advice/Remedies
The pipe auger does not start	Electricity supply is cut off	Check electric power cable and replace if necessary.
	The fuses of the motor are defect	Replace fuses
	The safety switch of the motor is defect	Replace the safety switch of the motor
	Motor is defect	Replace the motor
	Foreign object is blocking the pipe auger	Remove the foreign objects via suitable remedies
Motor stops / motor is overloaded	Foreign object is blocking the pipe auger	Remove the foreign objects via suitable remedies
	The outlet is blocked	Clean the outlet
	Too much transport material in the pipe auger	Adjust admission down to smaller quantities of transport material
	Electricity supply is cut off	Check electric power cable and replace if necessary.
	The fuses of the motor are defect	Replace fuses
The pipe auger does not transport / transports irregularly	The drive shaft is broken	Replace the drive shaft
	The inner auger is too worn	Replace the inner auger
	The inner auger is bent due to foreign object(s)	Remove the foreign object(s) via suitable tools, straighten out the inner auger, or replace if necessary
	The V-belt tension is too weak	Retighten the V-belt, replace if necessary
	Transport material is too much polluted	Clean the transport material
	The transport material is too moist	Dry transport material
	Insufficient material available	Add transport material



Declaration of Conformity

The Company
Søby Maskinaktieselskab
Viborgvej 306
DK-7840 Højslev
Denmark

Hereby declares that this machine type supplied by **Søby Maskinaktieselskab**

type: SS102-SS152

Complies with the following normative documents:

DIRECTIVE 2006/42/EC	OF THE EUROPEAN PARLIAMENT AND OF THE COUNCIL of 17 May 2006 on machinery, and amending Directive 95/16/EC
DIRECTIVE 2014/34/EU	OF THE EUROPEAN PARLIAMENT AND OF THE COUNCIL of 26 February 2014 on the harmonisation of the laws of the Member States relating to equipment and protective systems intended for use in potentially explosive atmospheres
DS/EN ISO 12100:2011	Safety of machinery – General principles for design – Risk assessment and risk reduction
DS/EN ISO 13857:2019	Safety of machinery – Safety distances to prevent hazard zones being reached by upper and lower limbs
DS/EN IEC 60079-0:2018	Explosive atmospheres – Part 0: Equipment – General requirements
DS/EN ISO 80079-36:2016	Non-electrical equipment for use in potentially explosive atmospheres Part 1: Basic method and requirements
DS/EN ISO 80079-37:2016	Non-electrical equipment for use in potentially explosive atmospheres Part 5: Protection by constructional safety 'c'
DS/EN ISO 1127-1:2011	Explosive atmospheres - Explosion prevention and protection - Part 1: Basic concepts and methodology

The electrical components mounted on this machine type complies with the following normative documents:

DIRECTIVE 2014/30/EU	OF THE EUROPEAN PARLIAMENT AND OF THE COUNCIL of 26 February 2014 on the harmonisation of the laws of the Member States relating to electromagnetic compatibility
DIRECTIVE 2014/35/EU	OF THE EUROPEAN PARLIAMENT AND OF THE COUNCIL of 26 February 2014 on the harmonisation of the laws of the Member States relating to the making available on the market of electrical equipment designed for use within certain voltage limits
DIRECTIVE 2011/65/EU	OF THE EUROPEAN PARLIAMENT AND OF THE COUNCIL of 8 June 2011 on the restriction of the use of certain hazardous substances in electrical and electronic equipment

This machine is designed for equipment group II category 3/- D and have the following marking.

   II 3D/- Ex IIIC 135C° Dc/- X

Højslev, Nov-22

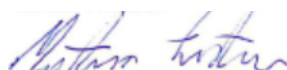

Morten Frantsen
Co-Owner



SOBY TRUSTED
SINCE 1961

Viborgvej 306 · DK-7840 Højslev
(+45) 97 53 50 33 · soby@soby.com
www.soby.com