

SOBY.COM
TRUSTED SINCE 1961



User manual

TLR

Thank you for choosing SØBY
In order for the machine to function
optimally, it is important to forllow the
instructions in this manual.

Enjoy.

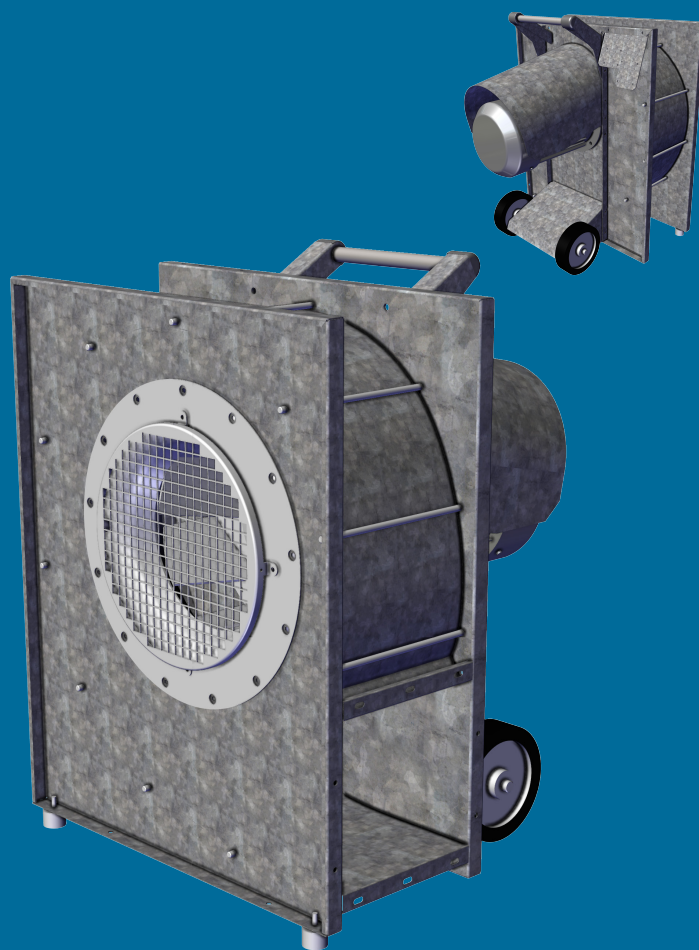

Introduction

Thank you for choosing SØBY.

It is very important that you read this user manual to obtain the necessary knowledge regarding installation, operation, service, maintenance, and dismantling. It is important to keep the user manual in a safe location for future use.

At SØBY we always work to improve our machines therefore we reserve the right to improve and update our products continually. This mean that some machine parts will be removed from the product selection, but it will always be possible to get a corresponding machine part for our machines. SØBY will always be ready to help and guide regarding our products.

Enjoy.

Contents

General Information.....	3
Use of the Machine.....	7
Explanation of the Pictograms.....	8
Residual Risk.....	9
Description of the Components.....	10
Technical Data and Specifications.....	11
Noise Values.....	13
Commissioning.....	14
Changing of the Fan Wheel.....	14
Dismounting of the Motor.....	16
Electrical Connection.....	17
Maintenance.....	18
Troubleshooting.....	19

General Information



Please read the entire User Instructions before assembling and operating the installation.

If the purchaser makes any technical modifications to the machine, then any warranty from SØBY will be cancelled. The declaration will lose its validity. The factory warranty does not include water damages or transportation damages or consequences thereof. Therefore, protect the fan from moisture and water. Likewise, the factory warranty will become void if the instructions in this guide are not followed.

The guarantee is only granted, if the following conditions are met:

- The unit only is to be used as described in this User Instructions. Replacement of parts or changing in the construction of the device might cause that the equipment must be re-certified.
- Assembly, putting into operation and operation only by using this User Instructions.
- Compliance with the intervals for maintenance in accordance with instructions must be documented.
- Only use the original spare parts of the manufacturer.
- The collection around the casing of the fan is sealed so that it will be airtight.
- Emergency stop must be installed in accordance w/ the current standard EN 60204-1.
- At normal operation at the machine, one must look into the pictogram devices and study the User/Assembly Instructions.
- Pay attention to the fact that the fan must be installed in such a way that there is optimum air supply from outside; only with fresh air the optimum drying/cooling is allowed.
- Position the fan in such a way that the airflow to the main channel is as straight as possible and see to it that no performance reducing measures are fitted at the blow-off nipple.
- At mounting of a warm air heater, the temperature of the intake-air must not exceed 55°, this may reduce the germination of the grain.
- When performing operations in areas where there might be a risk of explosion, the safety of personnel and equipment depends on compliance with the relevant safety regulations. Performing installation works and maintenance in such areas, involves a special responsibility of the personnel who are carrying out the works. The works mentioned requires that the assembly personnel and maintenance personnel have a thorough knowledge of laws, regulations and standards within the area. This construction provides a brief review of the most important safety issues, which are associated with installation, maintenance and use of the equipment. Please pay

attention to the fact, that the valid prescriptions, with the following requirements for zone classification and possible reporting to the local authorities, which are valid.

- Repair, service and maintenance must be performed carefully in strict compliance with the instructions of SØBY and must be performed by personnel who possess the qualifications required for the taking care of the explosion safety of the equipment. Inspection and maintenance must for the electrical equipment concerned be based on the instructions in EN60079-17.
- During the lifetime of the fan concerning the mechanical parts, and in connection with use, there must be a particularly focus on:
 - Service lifetimes (see chart)
 - Damages to parts and screens
 - Corrosion
 - After tightening of bolts and screws
- Modifications or alterations of the equipment, which influence the explosion safety of the equipment, are not allowed. Before using the equipment, check that the equipment is undamaged, assembled, and installed as directed by SØBY.

Attention is in particular drawn to:

- National Security Rules
- National Requirements to Safety and Health at Places of Work
- National Rules of Installation for the Type of Installation in Question
- Recognized Standards
- Safety Information in this Instructions for Operation
- Data and Information on the Permissible Installation and Operating Conditions of the Rating Plate
- Directions in any Type Certificates for Equipment installed on the Unit

The manufacturer reserves the right of performing technical changes.

	Particle Size [µm] [Microns]	Ignitions-temperature Cloud of Dust [°C]	Ignition Temperature 5mm Cloud of Dust [°C]	LEL [g/m³]	MIE [mJ]	Kst [bar m/s]	Reference
Grænse værdier	12	400	280	30	50	131	-

If the air contains stones, metal or other foreign objects, the explosion safety of the equipment cannot be guaranteed.

Must comply w/ EN 60079-10-2:2015 concerning explosive atmosphere / dust atmosphere.

Safety Instructions



The manual and especially information concerning safety must be read carefully prior to assembling, operating, servicing and maintaining.

All plants and components must be assembled in accordance with the relevant regulations for prevention of accidents.

The machine must be shielded correctly in relation to the relevant Machinery Directive. Therefore, that it will be impossible to encounter moving parts. The shielding may only be removed by using tools. The shielding must be mounted before the machine is put into operation.

The motor must be properly protected through overload protection equipment. Just like the fan properly must be ensured capable potential compensation.

At any repair or maintenance, the power source must be separated from the drive motor. As the fan wheel has a long time of coming to a standstill, one must before repair secure that, the fan wheel has totally standstill.

When fan is running, do not put your hand or your fingers into the drive device or elsewhere. One therefore must ensure that no people are near to the fan when it is going to be started. Likewise, make sure that the grid and outlet nipple are mounted correctly. In addition, the fan should always be mounted with transition nipple to silo or to air channel.

Shieldings must be maintained regularly.

The machine must be installed in such a way that there are ergonomic good conditions at service at the machine.

Prior to starting-up of the fan, one must ensure that all screws, bolts and trailed things are properly tightened.

All screws, bolts and trailers must be securely tightened.

The motor must be properly protected via overload protection equipment, as an overloading can produce an overheating. Always use gloves if the fan is stalled, or if it has just run. Likewise, it is recommended, that you let the fan stand for a few minutes prior to starting-up the repair of the machine.

The fan may only be put into operation when it is assured that it is not defect. The user is obliged only to operate the system, when it is in perfect condition.

SØBY is not liable for damages arising from misuse or technical alterations to the system and breach of the instructions given in these Instructions for Use.

If the fan is placed in areas classified as potentially explosive, use specially approved motor for the zone in question. If in doubt, please contact SØBY for

further information. It must be ensured that the ambient temperature in the area in which the equipment is going to be placed, remains within the allowed limit values of the equipment $-20^{\circ}\text{C} \leq \text{TA} \leq 40^{\circ}$. Therefore, one must, at installing of the unit take into account, that there might be possible heat sources that could affect the ambient temperature in the area in which the equipment is installed.

During any kind of work with the fan, there must be adequate work lighting

During any kind of work with the machine should be used safety boots, earmuffs and other required precautions as they might be required by the local workplace assessment, in which the fan is going to be installed. Furthermore, helmet must be used during installation, service and assembly/disassembly.

When assembling of machines, there might be heavy lifting. People who set up the machine must read the assembly/user manual at first. Suitable lifting equipment must be used in connection to installation and assembly.

As there might be a danger of sharp edges, one must use gloves when handling the machine.

The fan must be located in a dry place in order to avoid oxidation of engine and contacts.

The equipment must not be exposed to more dust impact (dust layers) than allowed in EN60079-14.

Use of the Machine

The fan is designed for drying and airing of grain or of other agricultural crops. The fan is driven by an electric motor, which is placed on the side of the fan. The fan takes in air through the suction and then blows the air out through the blowout. Under normal circumstances, the fan will be mounted with a nipple of blowout, and thereafter mounted with a nipple of connecting either to the silo or to the air channel.

The fan can have an effect from 1,1kW and up to 15kW, depending on the type of model.

The fan is not intended for extraction of air, gases, etc.
The intake air must not be heated to temperatures above 55° C. Failure to observing of the above will invalidate any warranty obligation.

Explanation of the Pictograms

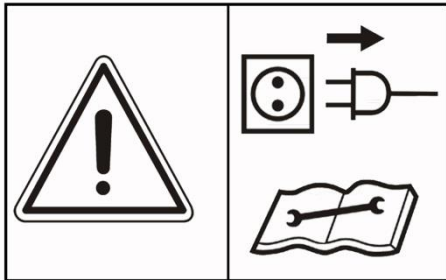

Prior to repair, maintenance and cleaning work the motor must be turned off and the electric plug pulled out.

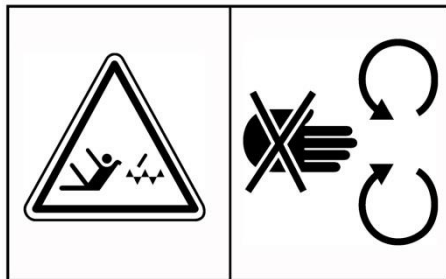

Moving parts can be dangerous.
All shieldings must be mounted before starting up of the machine



Hearing protection is required when working with this machine.



Centre of Gravity here.



The arrow indicates the direction of the fan wheels for rotating.

Residual Risk

The fan is produced in accordance with the health and safety requirements, which are set out in the ATEX and in the Machinery Directive, and in accordance with the consequently harmonized standards. If these regulations are disregarded, the fan might be a danger to the operator/user or to the life and limb of a third party. See Declaration of Conformity.

Description of the Components

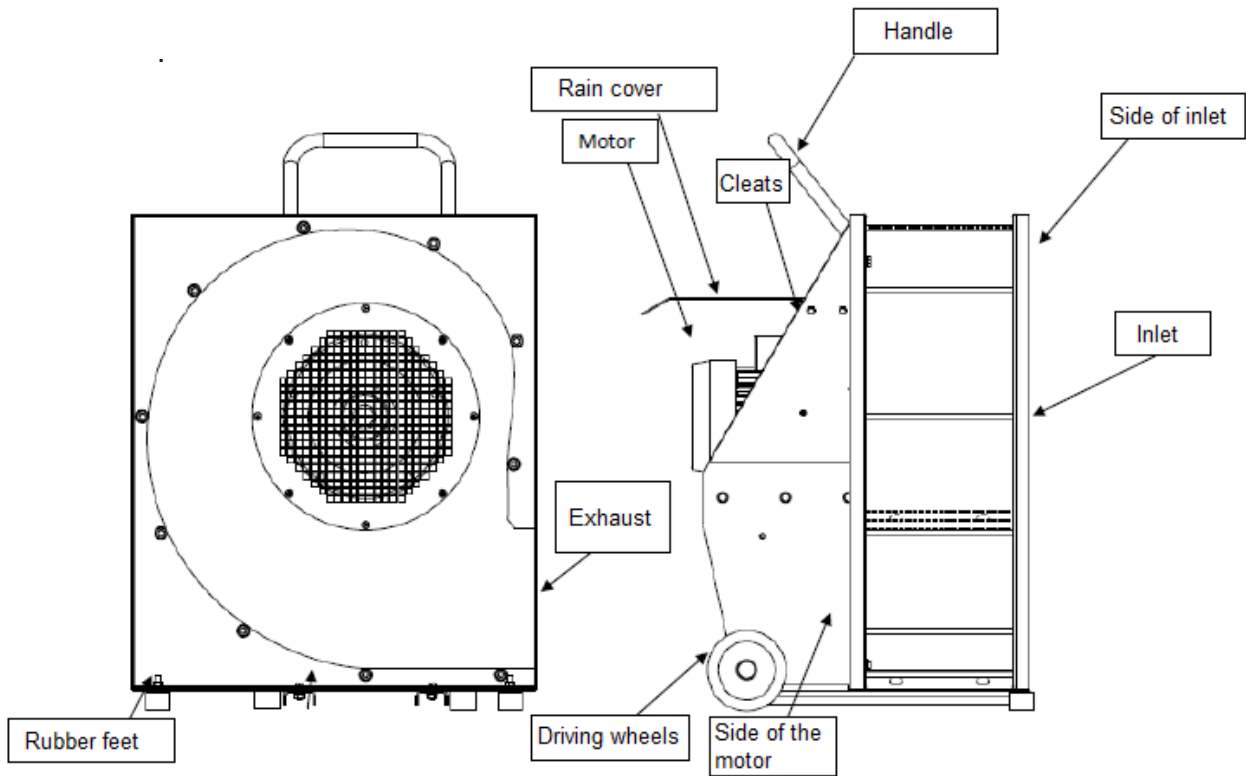

Technical Data and Specifications

Type	Ampere Consumption	Min. Fuses directly A	Min. Fuses Y/D A	Fuses Type	Weight kg
TLR 1,1 kW	2,50	10	-	Neozed	45
TLR 1,5 kW	3,30	10	-	Neozed	50
TLR 2,2 kW	4,70	10	-	Neozed	65
TLR 3,0 kW	6,20	10	-	Neozed	87
TLR 4,0 kW	7,70	-	16	Neozed	87
TLR 5,5 kW	10,10	-	16	Neozed	129
TLR 7,5 kW	13,30	-	25	Neozed	136
TLR 11 kW	19,30	-	35	Neozed	207
TLR 15 kW	26,20	-	50	Neozed	228

Flows are indicated at 400 V supply.

Be aware of limited running time in star connection, before delta connection.

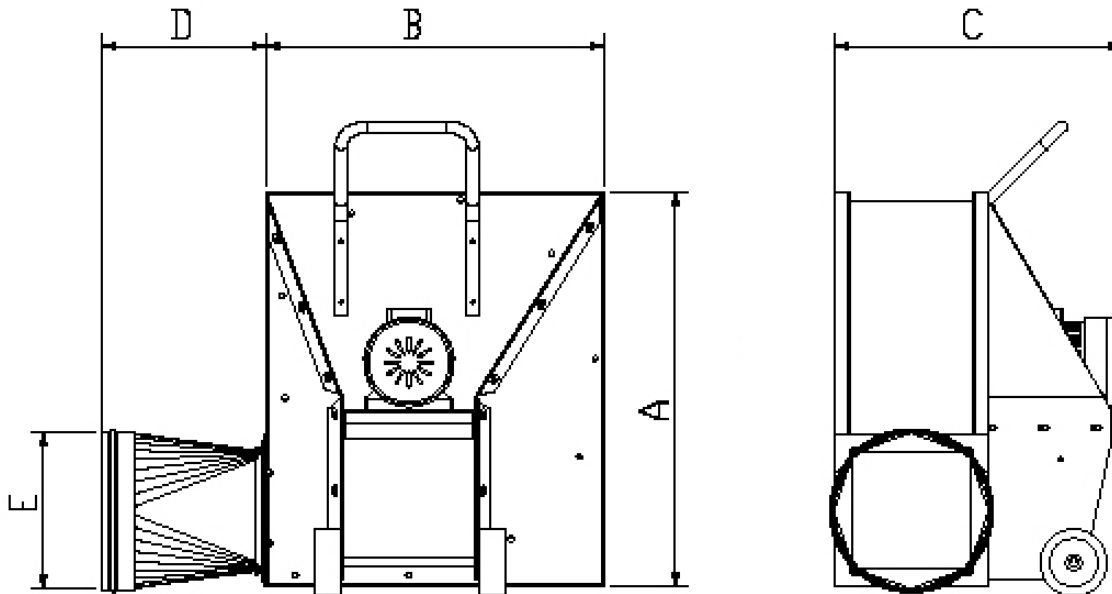

TYPE	KW	HK	A	B	C	D	E
TLR	1,1	1,5	553	485	483	180	150
TLR	1,5	2,0	615	555	436	180	150/200
TLR	2,2	3,0	760	645	551	230	200/300
TLR	3,0	4,0	760	645	551	230	300
TLR	4,0	5,5	760	645	630	275	300/400
TLR	5,5	7,5	930	735	683	275	300/400/500
TLR	7,5	10,0	930	735	776	310	300/400/500
TLR	11,0	15,0	1044	849	857	350	400/500
TLR	15,0	20,0	1044	849	857	350	400/500

Noise Values

The noise values measured in dB(A) at a distance from the fan of 1,5m

Type TLR

Size	Motor Side / Rear	Suction Side
1,5 kW	82	86
2,2 kW	84	89
4,0 kW	86	92
5,5 kW	86	92
7,5 kW	89	97
11,0kW	92	97
15,0kW	92	98

Commissioning

The fan must be placed onto a solid foundation of concrete in connection with a main channel, and it must be screwed firmly into the foundation by anchor bolts or by dowels.

If the fan is going to be mounted into a pipe or into a hose, one could use a circular fan nipple from the fan figure 1.

Figure 1.

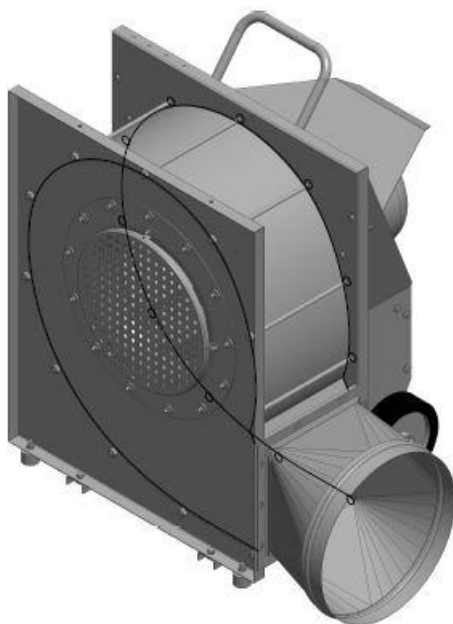

Changing of the Fan Wheel

Prior to starting up the changing work, one must secure that the electric power supply has been disconnected and that the fan wheel is standing totally still.

Start by dismantling the safety grate as shown in figure 2. Now the nozzle ring is to be dismantled as shown in figure 3.

Figure 2

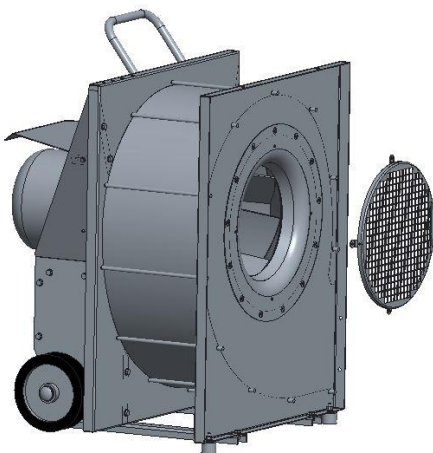
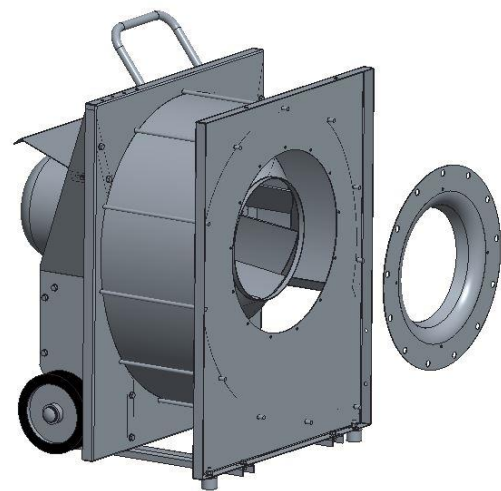
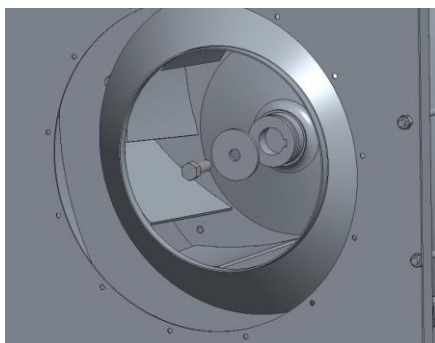

Figure 3



Now the bolt and the lock washer are ready to be dismantled as shown in figure 4, and the wheel here after can be drawn off. Using suitable lifting equipment for this task is important.

Figure 4



Dismounting of the Motor

In order to dismount the motor of the fan, it is predicted that the fan wheel is dismounted.

Start by dismounting of the rain cover as shown in figure 5. Now dismount the electrical connection, thereafter the four bolts, which hold the motor fixed as shown in figure 6.

Figure 5

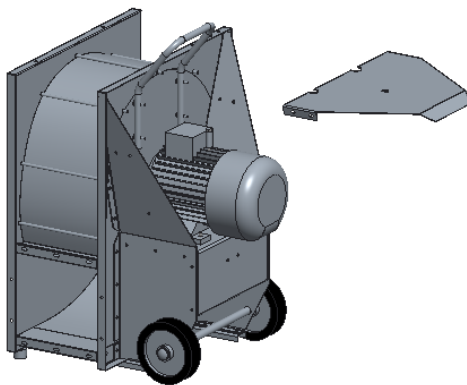
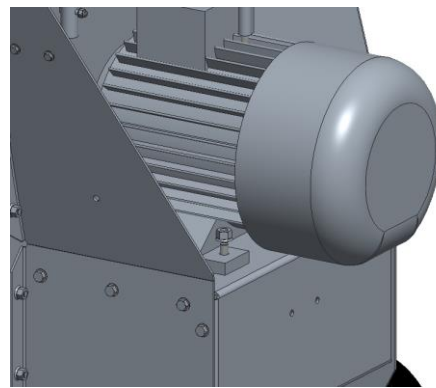
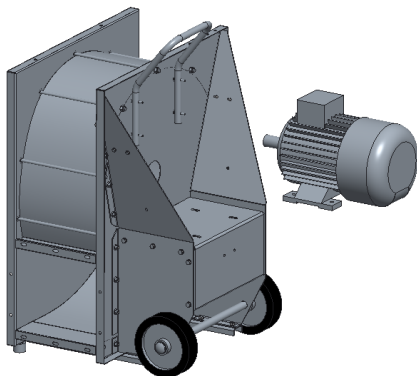

Figure 6



The motor now is ready for dismounting as shown in figure 7.

Figure 7



Electrical Connection

Specially trained staff may only perform the electrical connection to machinery delivered by SØBY.



During installation, be aware of the voltage and data indicated at the motor data plate.

The connection terminals of the motor are connected according to the instructions on the motor. The motor must be protected with thermal protection and by a lockable main cut-out switch, as the guarantee from the side of the manufacturer of the motor otherwise will become void (Thermal protection and main cut-out switch are not part of the delivery).

Installation of connection of the unit must take place in accordance with national rules of installation, supplemented by the demands, which are stated in EN60204-1 and EN60079-14. Starting up of the electrical parts and subsequent maintenance must be in accordance with the instructions in EN60079-17.

The fan must always be connected to protected motor switch by using of protected motor switch w/ star/delta switch (See table for data and specifications).

If a frequency converter or a soft starter are put in, one carefully has to take stock of data from the converter and from the data plate. Pay attention to the labeling of the electrical components in classified areas.

When connecting the fan one must ensure that the direction of rotation of the fan wheel matches the direction of rotation of the arrow.

Balancing of the potential:

An outside terminal for connection to the balancing connection exists on the motor.

The connection must be carried out in accordance with the instructions in EN60079-14.

Maintenance

During work of maintenance the measures described under "Safety Instructions" must be observed and put through.

Be aware that the safety of the motor and of the bearings are subject to the compliance with maintenance intervals/replacement.

At each starting-up, the intake grate must be cleaned.

The following equipment at the unit is going to be maintained with the following intervals:

Equipment	Manufacturer	Intervals of Maintenance:
Motor	Cantoni /techtop	Must be replaced at every 20.000 operating hours
Washers and nuts	Bossard	It must be controlled after 40 operating hours that all washers and nuts are properly tightened.
Fan Wheel	SØBY	Must be controlled every year before season. Check if fan wheel balances/ check if it shakes.

Troubleshooting

Errors	Possible Cause	Remedy
The fan does not start	Power supply interrupted	Check power cable and replace if necessary
	The motor fuses are defect	Replace fuses/adjust start procedure
	The motor safety switch is defect	Replace the motor safety switch
	Motor is defect	Replace the motor
	Foreign objects block the fan	Remove the foreign object via suitable remedies
The motor stops / is overloaded	Foreign objects block the fan	Remove the foreign object via suitable remedies
	The outlet/the out blowing has clogged	Clean the outlet
	Power supply interrupted	Check power cable and replace if necessary
	The motor fuses are defect	Replace fuses
The fan is not efficient / is irregular	Fan wheel is too worn	Renew/change
	Fan blades are bent due to foreign object	Remove the foreign object by suitable tools, straighten out the fan blades, or change them if necessary
Fan is shaking	Fan is not adjusted/straightened up or fitted	Adjust the under layer/mount the fan firmly
	Fan wheel out of balance or damaged during transportation/collision	If possible, straighten up or order spareparts



Declaration of Conformity

The Company
Søby Maskinaktieselskab
Viborgvej 306
DK-7840 Højslev
Denmark

Hereby declares that this machine type supplied by **Søby Maskinaktieselskab**

type: TLR

Complies with the following normative documents:

DIRECTIVE 2006/42/EC	OF THE EUROPEAN PARLIAMENT AND OF THE COUNCIL of 17 May 2006 on machinery, and amending Directive 95/16/EC
DIRECTIVE 2014/34/EU	OF THE EUROPEAN PARLIAMENT AND OF THE COUNCIL of 26 February 2014 on the harmonisation of the laws of the Member States relating to equipment and protective systems intended for use in potentially explosive atmospheres
DS/EN ISO 12100:2011	Safety of machinery – General principles for design – Risk assessment and risk reduction
DS/EN ISO 13857:2019	Safety of machinery – Safety distances to prevent hazard zones being reached by upper and lower limbs
DS/EN IEC 60079-0:2018	Explosive atmospheres – Part 0: Equipment – General requirements
DS/EN ISO 80079-36:2016	Non-electrical equipment for use in potentially explosive atmospheres Part 1: Basic method and requirements
DS/EN ISO 80079-37:2016	Non-electrical equipment for use in potentially explosive atmospheres Part 5: Protection by constructional safety 'c'
DS/EN ISO 1127-1:2011	Explosive atmospheres - Explosion prevention and protection - Part 1: Basic concepts and methodology

The electrical components mounted on this machine type complies with the following normative documents:

DIRECTIVE 2014/30/EU	OF THE EUROPEAN PARLIAMENT AND OF THE COUNCIL of 26 February 2014 on the harmonisation of the laws of the Member States relating to electromagnetic compatibility
DIRECTIVE 2014/35/EU	OF THE EUROPEAN PARLIAMENT AND OF THE COUNCIL of 26 February 2014 on the harmonisation of the laws of the Member States relating to the making available on the market of electrical equipment designed for use within certain voltage limits
DIRECTIVE 2011/65/EU	OF THE EUROPEAN PARLIAMENT AND OF THE COUNCIL of 8 June 2011 on the restriction of the use of certain hazardous substances in electrical and electronic equipment

This machine is designed for equipment group II category 3/- D and have the following marking.

   II 3D/- Ex IIIC 135C° Dc/- X

Højslev, Nov-22

Morten Frantsen
Co-Owner



SOBY TRUSTED
SINCE 1961

Viborgvej 306 · DK-7840 Højslev
(+45) 97 53 50 33 · soby@soby.com
www.soby.com